

# CRAPAUDS STANDARD / STANDARD CLIPS

FIXATION DE RAIL VIGNOLE ET PONT ROULANT / VIGNOLE AND CRANE RAIL FIXING

**Pose :**

Il est conseillé de les placer en vis-à-vis tous les 600 mm.

Le crapaud à talon nécessite une traverse métallique spécialement percée à cet effet.

**Protection :**

Goudronné  
Possibilité de galvanisation

**Laying:**

We advise to fasten clips opposite side every 600 mm.

Sleeper clips with stop heel requires steel sleeper suitably punched.

**Protection :**

Tarred  
Possibility of galvanization.

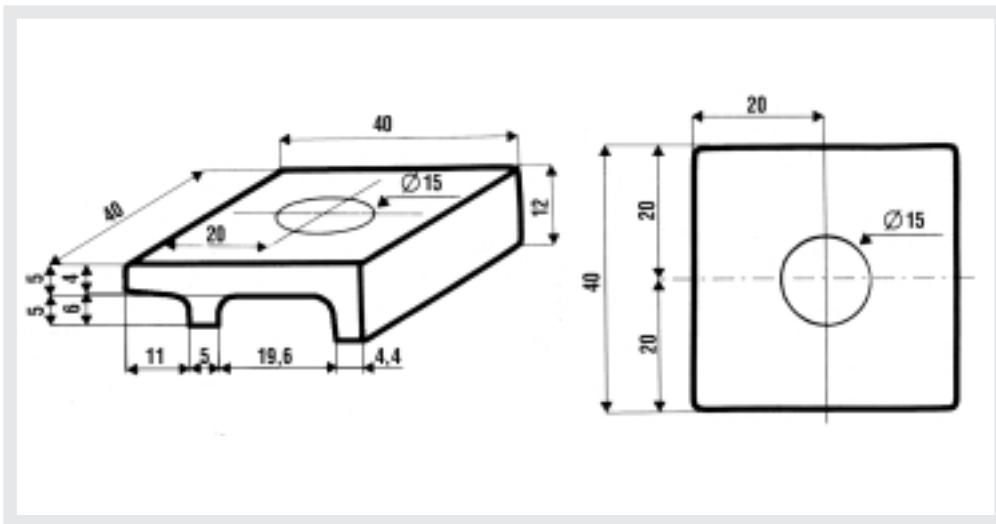

**N° 5**

ADAPTABLE AUX RAILS  
TYPE S 7  
40 x 40 trou Ø 15 mm

SUITABLE FOR RAILS  
TYPE S 7  
40 x 40 Ø 15 mm hole

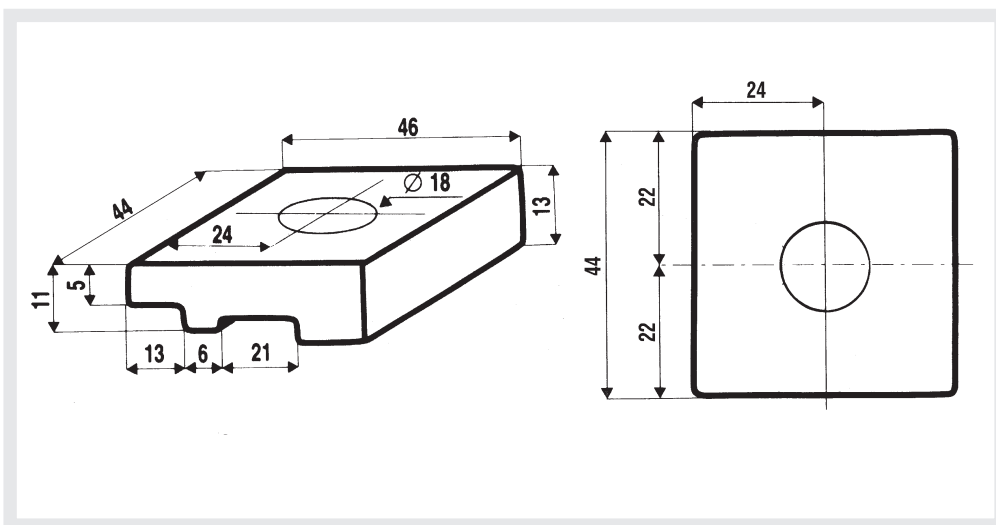

**N° 6**

ADAPTABLE AUX RAILS  
TYPE S 10 - S 14 - S 18  
44 x 46 trou Ø 18 mm

SUITABLE FOR RAILS  
TYPE S 10 - S 14 - S 18  
44 x 46 Ø 18 mm hole



LE SPÉCIALISTE DU RAIL ET MANUTENTION SUR RAIL  
RAIL AND ON-RAIL HANDLING SPECIALIST

SIEGE SOCIAL - REGISTERED OFFICE  
23, rue de la Boétie - 75008 PARIS - FRANCE  
S.A. au capital de 400.000 € - Limited Company with a capital of 400.000 €  
SIREN 702 033 077 - NAF 352Z

SERVICES COMMERCIAUX - COMMERCIAL SERVICES  
24, rue du 8 Mai 1945 - 95340 PERSAN - FRANCE  
Tél. : 01 39 37 45 45 - Fax : 01 39 37 45 44  
www.patry.fr - e-mail : info@patry.fr

# CRAPAUDS STANDARD / STANDARD CLIPS

FIXATION DE RAIL VIGNOLE ET PONT ROULANT / VIGNOLE AND CRANE RAIL FIXING

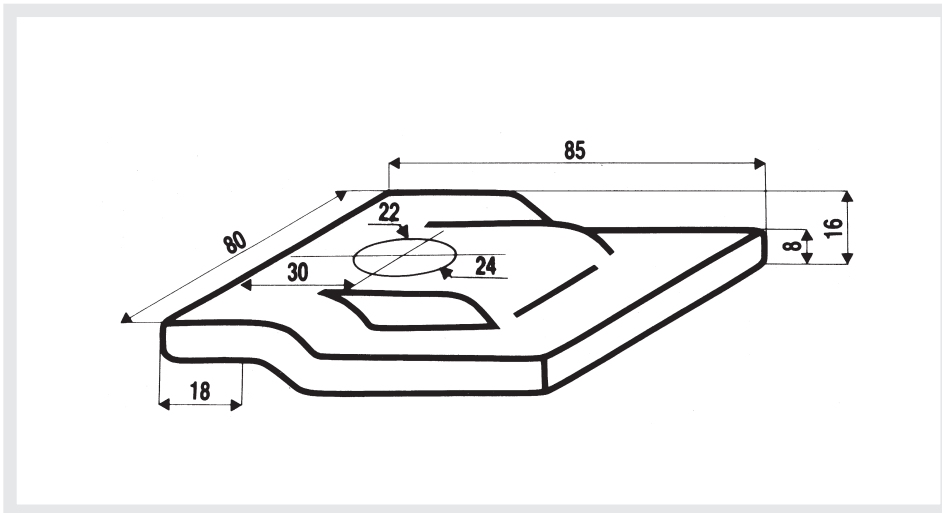

N° 10

ADAPTABLE AUX RAILS  
 TYPE S 20 - 26 KG - S 30 - 36 KG  
 46 KG - 50 KG - 54 KG  
 80 x 85 trou Ø 22 ou 24 mm

SUITABLE FOR RAILS  
 TYPE S 20 - 26 KG - S 30 - 36 KG  
 46 KG - 50 KG - 54 KG  
 80 x 85 Ø 22 or 24 mm hole

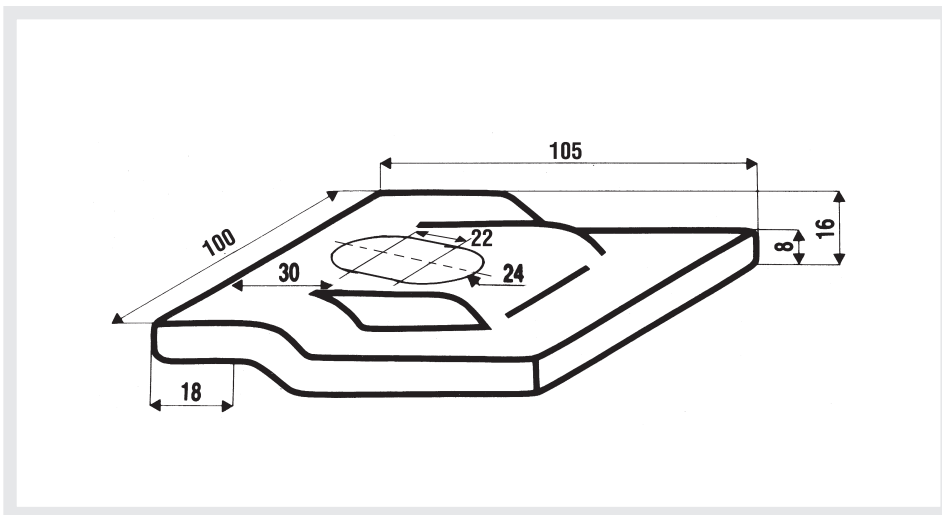

N° 10 TROU OBLONG

ADAPTABLE AUX RAILS  
 TYPE S 20 - 26 KG - S 30 - 36 KG  
 46 KG - 50 KG - 54 KG  
 100 x 105 trou 24 x 46 mm

SUITABLE FOR RAILS  
 TYPE S 20 - 26 KG - S 30 - 36 KG  
 46 KG - 50 KG - 54 KG  
 100 x 105 24 x 46 mm hole

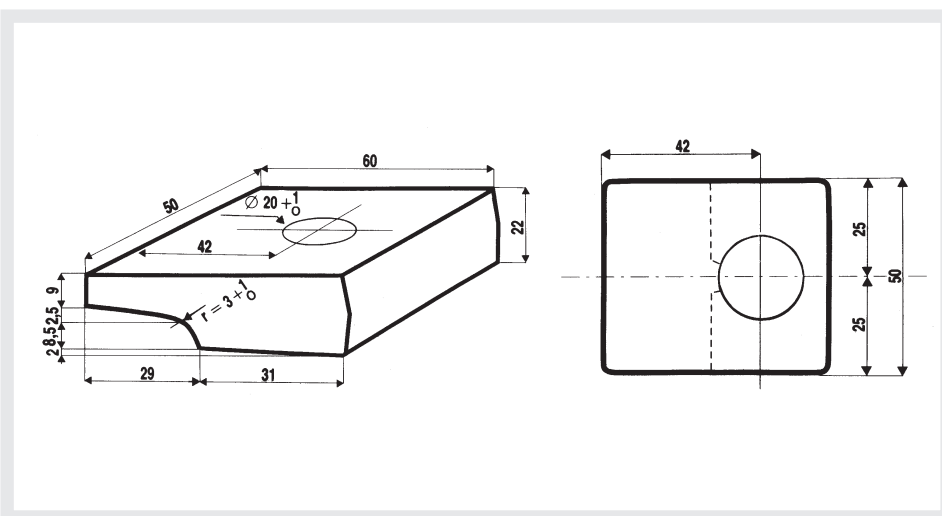

N° 11

ADAPTABLE AUX RAILS  
 TYPE 46 KG ET 50 KG  
 PONT ROULANT N° 3  
 60 x 50 trou Ø 20 mm

SUITABLE FOR RAILS  
 TYPE 46 KG AND 50 KG  
 CRANE RAILS N° 3  
 60 x 50 Ø 20 mm hole



LE SPÉCIALISTE DU RAIL ET MANUTENTION SUR RAIL  
 RAIL AND ON-RAIL HANDLING SPECIALIST

SIEGE SOCIAL - REGISTERED OFFICE  
 23, rue de la Boétie - 75008 PARIS - FRANCE  
 S.A. au capital de 400.000 € - Limited Company with a capital of 400.000 €  
 SIREN 702 033 077 - NAF 3522

SERVICES COMMERCIAUX - COMMERCIAL SERVICES  
 24, rue du 8 Mai 1945 - 95340 PERSAN - FRANCE  
 Tél. : 01 39 37 45 45 - Fax : 01 39 37 45 44  
 www.patry.fr - e-mail : info@patry.fr

# CRAPAUDS STANDARD / STANDARD CLIPS

FIXATION DE RAIL VIGNOLE ET PONT ROULANT / VIGNOLE AND CRANE RAIL FIXING

N° 7

ADAPTABLE AUX RAILS  
TYPE 30 KG S 30  
60 x 50 trou carré 22 mm

SUITABLE FOR RAILS  
TYPE 30 KG S 30  
60 x 50 22 mm square hole

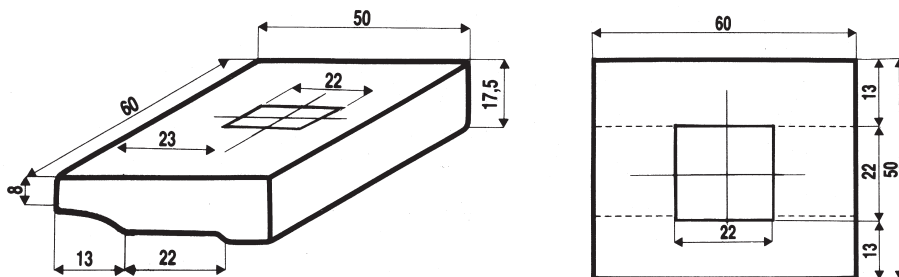

N° 8

ADAPTABLE AUX RAILS  
TYPE S 20 - 26 KG ET S 30  
80 x 56 trou Ø 20 mm

SUITABLE FOR RAILS  
TYPE S 20 - 26 KG AND S 30  
80 x 56 Ø 20 mm hole

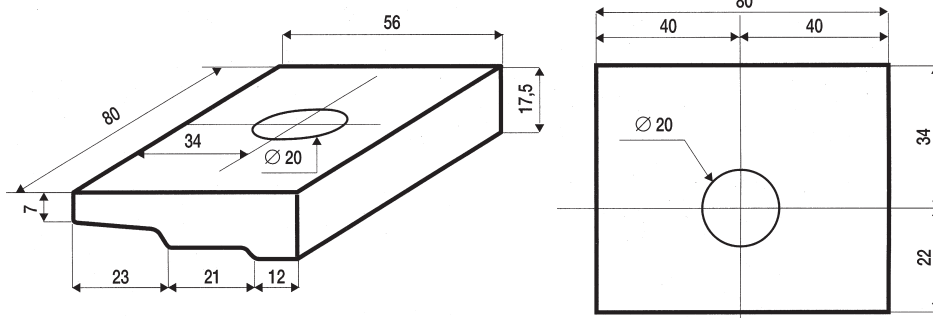

N° 9

ADAPTABLE AUX RAILS  
TYPE 36 KG - 46 KG ET 50 KG  
64 x 65 trou Ø 26 mm

SUITABLE FOR RAILS  
TYPE 36 KG - 46 KG AND 50 KG  
64 x 65 Ø 26 mm hole

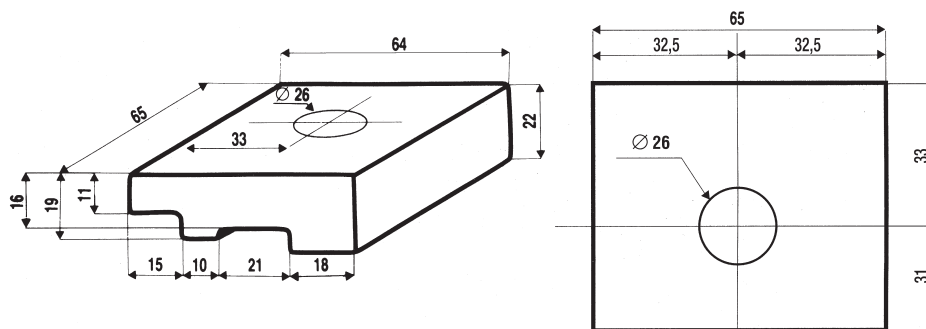

LE SPÉCIALISTE DU RAIL ET MANUTENTION SUR RAIL  
RAIL AND ON-RAIL HANDLING SPECIALIST

SIEGE SOCIAL - REGISTERED OFFICE  
23, rue de la Boétie - 75008 PARIS - FRANCE  
S.A. au capital de 400.000 € - Limited Company with a capital of 400.000 €  
SIREN 702 033 077 - NAF 352Z

SERVICES COMMERCIAUX - COMMERCIAL SERVICES  
24, rue du 8 Mai 1945 - 95340 PERSAN - FRANCE  
Tél. : 01 39 37 45 45 - Fax : 01 39 37 45 44  
www.patry.fr - e-mail : info@patry.fr

# CRAPAUDS STANDARD / STANDARD CLIPS

FIXATION DE RAIL VIGNOLE ET PONT ROULANT / VIGNOLE AND CRANE RAIL FIXING

N° 12

ADAPTABLE AUX RAILS  
TYPE 46 KG A 60 KG  
PONT ROULANT N° 4 ET N° 5  
60 x 70 trou Ø 22 mm

SUITABLE FOR RAILS  
TYPE 46 KG TO 60 KG  
CRANE RAILS N° 4 AND N° 5  
60 x 70 Ø 22 mm hole

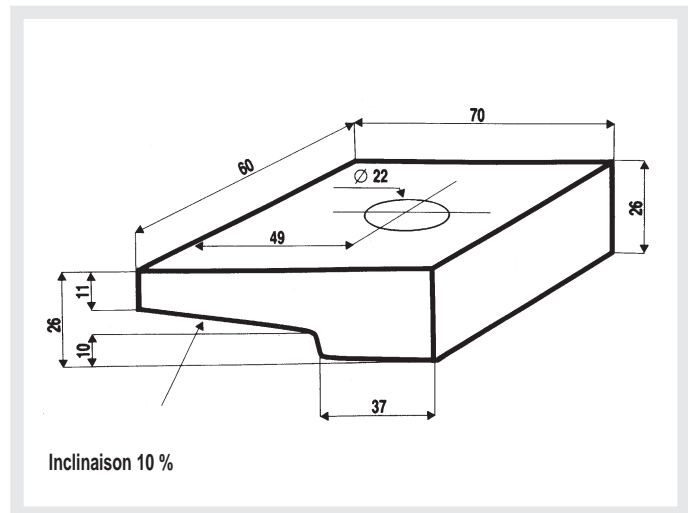

N° 13

ADAPTABLE AUX RAILS  
PONT ROULANT N° 1 ET N° 2  
60 x 60 trou Ø 18,5 mm

SUITABLE FOR RAILS  
CRANE RAILS N° 1 AND N° 2  
60 x 60 Ø 18,5 mm hole

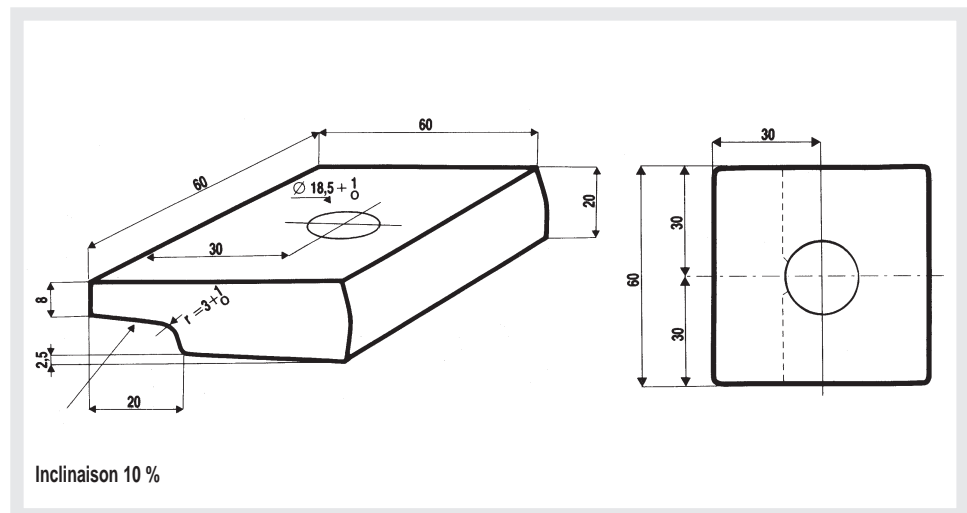

N° 14 TROU OBLONG

ADAPTABLE AUX RAILS  
PONT ROULANT N° 6 ET N° 7  
100 x 80 trou 23 x 40 mm

SUITABLE FOR RAILS  
CRANE RAILS N° 6 ET N° 7  
100 x 80 23 x 40 mm hole

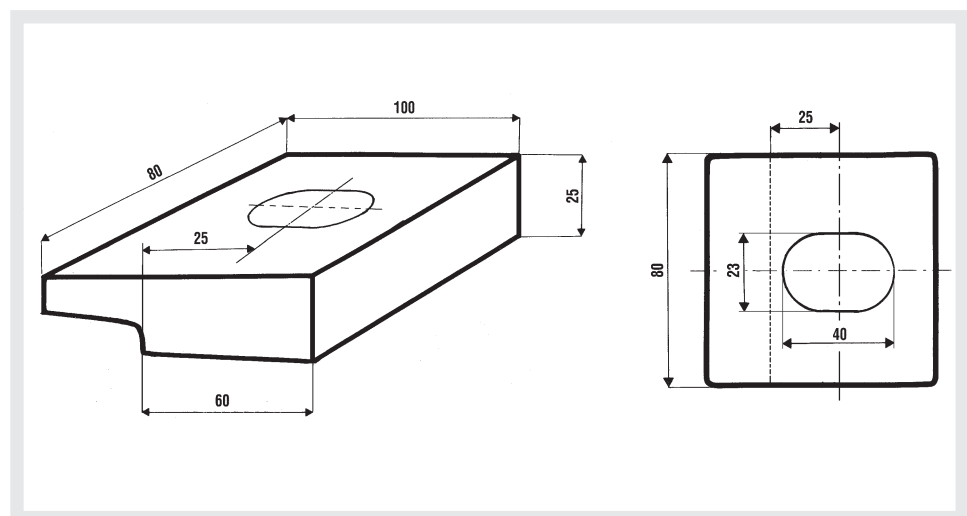

LE SPÉCIALISTE DU RAIL ET MANUTENTION SUR RAIL  
RAIL AND ON-RAIL HANDLING SPECIALIST

SIEGE SOCIAL - REGISTERED OFFICE

23, rue de la Boétie - 75008 PARIS - FRANCE  
S.A. au capital de 400.000 € - Limited Company with a capital of 400.000 €  
SIREN 702 033 077 - NAF 352Z

SERVICES COMMERCIAUX - COMMERCIAL SERVICES

24, rue du 8 Mai 1945 - 95340 PERSAN - FRANCE  
Tél. : 01 39 37 45 45 - Fax : 01 39 37 45 44  
www.patry.fr - e-mail : info@patry.fr